

INSTRUCTIONS

APPLICATOR iPad/iPhone/iPod Access Device

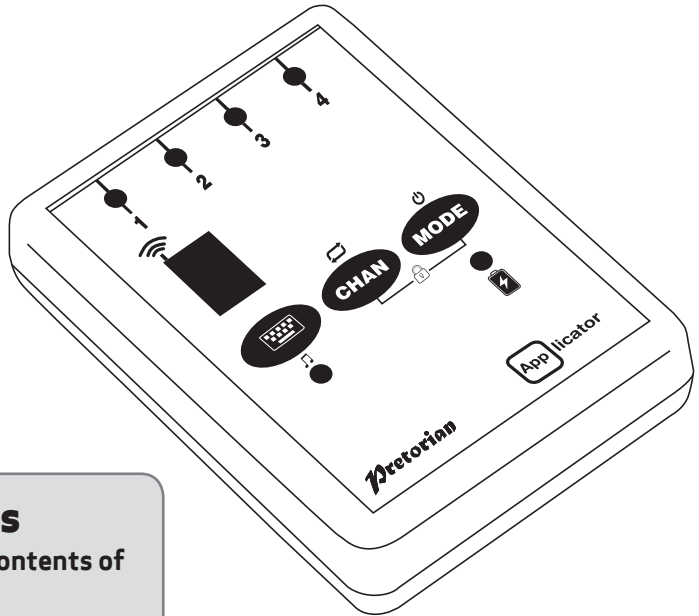

Pack Contents

Carefully check the contents of the box, which are:

- APPLICATOR unit**
- USB charging cable**
- These instructions**

Product Description

APPLICATOR is a switch access device specifically designed for the iPad/iPhone/iPod and is the only single device to give you access to both switch adapted apps, music and photography. Specifically designed around users' needs, APPLICATOR is simple to set up

and use, but loaded with features to cater for all requirements. Although simple to operate, to ensure you get the best experience from using your new APPLICATOR, please take time to read this instruction booklet.

- Pairs directly with your iPad/iPhone/iPod without PIN entry.
- Connect up to four wired switches of any type.
- Function of each socket may be individually selected.
- QuickMedia™ mode allows instant access to media player functions.
- Integral button allows on-screen keyboard to be displayed or hidden at any time.
- Manual Power-Off button
- Button Lock feature to prevent accidental/ unauthorised changes to settings.
- Single Shot setting to prevent multiple activations
- 20m (64') operating range.
- Integral lithium-ion rechargeable battery.
- Charged from any USB socket.

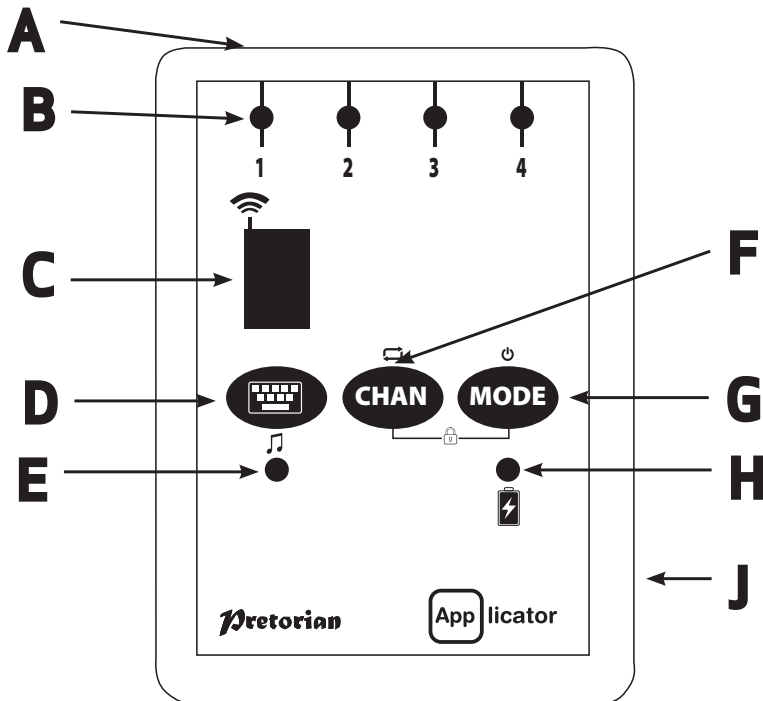

Compatibility

Your **APPLICator** is compatible with the following Apple products:

iPad - all models
iPod Touch 3rd Generation onwards
iPhone 3GS onwards

APPLICator is also compatible with other types of tablet- for example Android and PC tablets such as Surface, although certain features are Apple specific and may not work with other tablet devices.

Throughout these instructions, all references to iPad should be taken as meaning any of the above products.

Charging your APPLICator

Ensure that the integral battery is fully charged by plugging the charging cable into **APPLICator** and then into a computer USB port. The charging LED (H) will illuminate green to show that charging is taking place. Once charged, the charging light is extinguished.

Connecting to your iPad/iPhone/iPod

Wake up **APPLICator** by pressing any button. The display (C) will begin to show a rotating pattern to indicate it is searching for a device to connect with. If you don't see this pattern, refer to the 'Re-Connecting your **APPLICator**' section of these instructions.

Go to the Bluetooth menu on your iPad (Settings ➤ Bluetooth). First of all ensure Bluetooth is turned on using the slider at the top of the screen.

After a few seconds the **APPLICator** should appear as a 'discoverable' device. It will appear as something similar to:

Pretorian-V49.3-ABC1

Tap on the name and the pairing process will begin. Typically it takes around 20 seconds to connect, after which the iPad will state that the device is 'Connected'. Your **APPLICator** is now ready for use.

Notes about Bluetooth Connections

Once connected with a particular iPad, it will no longer be visible ('discoverable') by other iPads. If you turn your iPad off, turn off Bluetooth or if you go out of range of the **APPLICator**, the connection between the two devices is automatically re-established when you next power on, turn Bluetooth on or go back into range.

If you wish to connect with a different iPad at any time, please refer to the 'Re-Connecting your **APPLICator**' section of this manual.

Accessing switch-adapted Apps.

First of all, plug up to four wired switches into the sockets provided (A). Any switch with a standard 3.5mm plug may be used, including sip/puff, pad switches, grasp switches etc.

The default modes for the sockets are given in Table 1:

Socket	Default Mode
1	Space
2	Enter
3	~1
4	~3

Table 1: Default Socket Modes

Although the default settings cover the vast majority of switch adapted Apps, you may wish to make some changes to suit your preferences.

To change any setting, first select the channel which you would like to change by repeatedly

pressing the Channel button (F) until the LED (B) adjacent to that channel is illuminated.

The current setting is then shown on the display (C). To change, press the Mode button (G) until the desired setting appears on the display. Table 3 shows the available settings. After a few seconds the display is extinguished to save power and the setting saved.

This process may be repeated for any number of sockets.

Any combination of settings can be programmed, including duplicates, should you wish to use **APPLICATOR** for turn-taking and cooperation.

Mode Setting	Class	Function
0	Keyboard	Numeral 0
1	Keyboard	Numeral 1
2	Keyboard	Numeral 2
3	Keyboard	Numeral 3
4	Keyboard	Numeral 4
5	Keyboard	Space
6	Keyboard	Enter
7	Keyboard	~1
8	Keyboard	~3
9	Keyboard	Up Arrow
A	Keyboard	Down Arrow
B	Keyboard	Left Arrow
C	Keyboard	Right Arrow
D	Op. System	Keyboard
E	Media	Play/Pause
F	Media	Skip Forward
G	Media	Skip Back
H	Media	Volume Up
J	Media	Volume Down
L	Media	Mute
P	Media	Timed Play 10s
R	Media	Timed Play 30s
T	Switch Control	Home
U	Switch Control	Enter / Home

Table 3: Switch Functions

Accessing Music/Media

Many of the settings in Table 3 give access to the iPad media player rather than to switch adapted Apps. Any channel may be programmed to use

these settings and they may be mixed with switch adapted App settings in any sequence at all. Select these settings exactly as described above.

QuickMedia™ Mode

QuickMedia™ mode is designed to allow you rapid access to the iPad media player without needing to re-program the unit. Typically, you may be using a switch adapted App, during which time you would like to listen to a passage of music. This is easily achieved using APPLICATOR without even quitting your switch adapted App!

Simply press and hold the QuickMedia™ button (D). QuickMedia™ LED (E) lights and the sockets now assume the fixed functions given in Table 2.

Socket	Default Mode
1	Play/Pause
2	Skip Forward
3	Skip Back
4	Timed Play (10 sec)

Table 2: QuickMedia™ functions

(Please see notes below on using Timed Play settings).

Once in QuickMedia™ Mode, pressing any switch gives the functions listed in Table 2. Your iPad is designed to allow the media player to be accessible from within any other App, so if you're busy using another App, there's no need to quit.

Pressing and holding the QuickMedia™ button once more returns you to normal operation and the QuickMedia™ LED is extinguished.

On-Screen Keyboard

Because your APPLICATOR appears to the iPad as a keyboard, the iPad automatically turns off the on-screen keyboard. This can cause difficulties in some Apps which require a typed input such as entering a user's name.

To overcome this, APPLICATOR allows you to deploy the on-screen keyboard manually at any time. Simply press the QuickMedia™ button (D) briefly and the on-screen keyboard will be deployed automatically. To turn it off again, press the QuickMedia™ button briefly once again.

Mode setting 'D' allows any switch to be configured to deploy the on-screen keyboard. Note that iPad remembers your on-screen keyboard preference so there's no need to press to deploy every time.

Note that the iPad only allows the on-screen keyboard to be deployed when a text input box is selected.

Timed Play

Timed Play settings allow you to create a 'reward' for pressing a button, completing a task, or any number of other outcomes. You have a choice of 10 or 30 seconds play time.

Because this setting uses the 'Play/Pause' command, it is important that the iPad is paused (not playing) before you press the switch to give timed play, otherwise the iPad will pause for a timed period instead of playing.

If a switch programmed to Play/Pause is pressed during a timed play, the timed play will be cut

short and the unit will be Paused.

Skip Forward and Skip Back commands have no effect on the duration of a timed play.

If you wish to end a timed play early, you can either use a switch already programmed to Play/Pause or you can switch to QuickMedia™ and use switch 1.

Switch Control (iOS7 onward)

iOS7 and later operating systems include the Switch Control feature, allowing the user to scan apps, menu items and the pop-up keyboard without using the touch screen. **APPLICATOR** may be used as the Bluetooth switch device to allow you to scan and select items.

Before enabling Switch Control, first decide what type of switch interface will be best for the user. For example, this could be a single select switch in combination with the Auto Scanning feature within Switch Control, or it may comprise several switches to allow manual scanning and select.

Almost any switch setting in Table 3 categorised as 'Keyboard' may be used to effect any scanning/ selecting function. However, it is important not to use ~1 or ~3, since iPad accepts the first character only and both of these begin with ~. Media functions such as Play/Pause, Skip Fwd etc cannot be used.

Once you have decided on a particular number of switches, plug them into **APPLICATOR** and program their respective settings as described above. For example, if three switches are required for Scan to Next Item, Scan to Previous Item and Select Item it may make sense to use →, ← and Enter (B, C and 6 respectively on the display).

With **APPLICATOR** already paired to your iPad, go to Settings → General → Accessibility → Switch Control and tap on 'Switches'. Then tap on 'Add New Switch' and 'External'. You will be asked to activate your external switch. At this point, press the relevant switch plugged into **APPLICATOR**.

Once your iPad has recognised the keystroke, it will ask you to assign it to a particular task from a list. Using the above example, if you are setting up the → switch (setting B), you would tap on Scan to Next Item.

Repeat this exercise for each of the switches you would like to use and then turn on Switch Control using the slide at the top of the screen. Also set Auto Scanning to the desired setting (auto scanning will be disabled if you have pressed any switches that are set to Scan to Next Item or Scan to Previous Item). Generally speaking, fewer switches will be required when Auto Scanning compared to manual scanning so the choice of which to use is often governed by the number of switches the user is able to operate.

Tutorial videos are available on the Pretorian Technologies' website - please visit www.pretorianuk.com/applicator and click on Videos.

Using Home functions with Switch Control

Settings T and U in Table 3 have been added to make **APPLICATOR** easier to use with Switch Control. Setting T is 'Home' and is exactly equivalent to pressing the Home button on iPad. Note that this setting can be used whether in Switch Control or not and does not need to be programmed within Switch Control.

Setting 'U' is Enter/Home which gives Enter if pressed briefly or Home after an extended press. This is extremely useful when combined with Auto Scanning since it allows a single switch to carry out virtually every task on iPad.

To get the best experience from this switch, program Enter (brief press) to Select Item. Be sure to use a brief press when iPad asks you to activate your external switch and then set it to Select Item.

There is no need to set a function for Home (long press) since this is an inherent function for iPad. Once set up in this way, a brief press of the switch allows you to control Auto Scanning and select an item whereas a long press allow you to quit back to the home screen.

Re-Connecting your APPLICATOR

If, when waking up your **APPLICATOR**, the rotating pattern does not appear on the display, this indicates that the unit is already connected to another iPad in the vicinity. In this case you will need to 'forget' this connection before you can re-connect with another unit.

Similarly, if you have been using your **APPLICATOR** with a particular iPad that is still in the vicinity and you wish to swap it to another, you will also need to forget the existing connection.

Go to the Bluetooth menu on your iPad (Settings → Bluetooth) and tap the blue ⓘ symbol adjacent to the unit name, for example:

Pretorian-V49.3-ABC1

Then tap on 'Forget this device'. At this point the unit is no longer connected with the original iPad and will appear as a 'discoverable' device on all iPads in the vicinity. You can then re-connect with a different iPad by again tapping on the unit name in the Bluetooth menu.

Automatic Sleep Mode

To conserve battery life, **APPLICATOR** automatically enters a low-power sleep mode if it remains unused for 30 minutes. Pressing any external switch or any button on the unit instantly wakes it again. While asleep, the connection with the

iPad is lost but is automatically re-established within a few seconds of wake-up.

If the unit remains unpaired for more than 5 minutes, it will also enter low-power sleep mode. Press any button or switch to wake the unit.

Manual Power Off

When **APPLICATOR** is being moved around, especially with switches still plugged in, it is advisable to manually power the **APPLICATOR** down to prevent switch presses during transit from repeatedly waking up the unit and using up battery charge.

To power the unit down, press and hold **MODE (G)** until all four channel LEDs (**B**) light and then release. Pressing switches will no longer wake the unit. To wake it up and automatically reconnect over Bluetooth, press any button on **APPLICATOR**.

Button Lock

To prevent unintentional/ unauthorised changes to **APPLICATOR**'s settings, the unit may be locked so that button presses have no effect.

To Lock the unit, press and hold **MODE (G)** and **CHAN (F)** together. The display will show 'L'.

To Unlock, press and hold **MODE** and **CHAN** again until the display shows 'U'. When locked, you can still view the channel settings but any attempt to change them will bring up the 'L' symbol.

Single-Shot mode

Single-shot mode allows each switch to output a single keystroke no matter how long it remains pressed. This is useful for users who find it difficult to remove their hands from the switch quickly enough to prevent multiple keystrokes being sent to the device. It can prevent multiple instances of functions and is particularly useful with media functions such as Skip Forward and Skip Back.

Single-shot functionality may be set on each channel individually. Press and hold CHAN (F) and after a few seconds the first channel LED lights and on the LED display you will see either one bar (single-shot) or three bars (repeating)- see Figure 1. To change the setting, press MODE (G). To move to the next channel, press CHAN *briefly*. Once you have set each channel to the required setting, the LEDs will be extinguished after a few seconds and the settings saved. All channels are repeating by default.

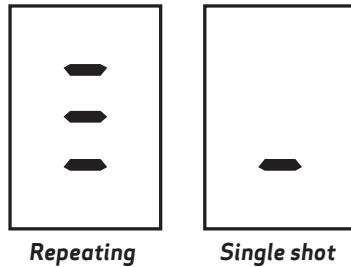

Figure 1

Battery Life and Battery Charging

A fully charged battery gives approximately 15 hours of use. When the battery is getting low, the Charging LED (H) begins to blink. This is an indication that you should charge the battery soon.

Plug the charging cable into the charging socket (J) and then into a USB socket on a computer. Ensure the computer is turned on.

While charging, the Charging LED will be illuminated. Once charging is complete (a matter of a few hours if fully discharged) the charging LED will be extinguished. You can then unplug the cable.

Note that you can carry on using APPLICATOR while it is charging.

Should you mislay the charging cable, replacements can be purchased by asking your local electrical retailer for a camera connection lead. It has a USB type A plug at one end and a mini-USB plug at the other.

APPLICATOR plugs into a computer USB port for charging purposes only - it does not give a functional connection this way.

Maintenance

Your APPLICATOR has no user serviceable parts. If repair is necessary the unit should be returned to Pretorian Technologies or an authorised distributor.

APPLICATOR contains a lithium ion battery that isn't user replaceable. Although the unit uses the very latest battery technology, it may eventually need to be replaced. Please return the unit to Pretorian Technologies for such replacement.

Disposal of batteries is often subject to local laws. Please consult your local authorities for information relating to your locale. Never dispose of a battery in fire.

Troubleshooting

If your **APPLICATOR** doesn't operate correctly, please use the following guide to determine the cause. If, after following this guide, your unit still doesn't operate, please contact your supplier before returning it.

Symptom	Possible Cause/ Remedy
My APPLICATOR is not 'discoverable' on my iPad	<ul style="list-style-type: none">• Ensure battery is charged.• Ensure unit is awake by pressing any button.• Unit may be connected with another iPad which is in range. Use 'forget this device' in Bluetooth menu of other iPad to make unit available again.
My APPLICATOR has been connected to this iPad before but won't connect now.	<ul style="list-style-type: none">• Re-connection should be automatic but if difficulties persist, try 'forget this device' and then re-connect. This usually resolves any connection issues.
When I select timed play, the music stops.	<ul style="list-style-type: none">• Ensure iPad playback is paused before selecting a timed play.
My APPLICATOR is connected to my iPad but the chosen switch functions don't work.	<ul style="list-style-type: none">• Check that the unit is not in QuickMedia™ Mode. If it is, press the QuickMedia™ button to return to normal Mode.
My APPLICATOR doesn't send anything to the tablet when I press switches	<ul style="list-style-type: none">• Unit may have been manually powered down. Press any button to awaken it.

Warranty

Your **APPLICATOR** is warranted against defects in manufacture or component failure. The unit is designed for domestic and educational applications. Use outside these areas will invalidate the warranty. Unauthorised repair or modification, mechanical abuse, immersion in any liquid or connection to incompatible equipment will also invalidate the warranty.

The Apple, Android and Surface[®] brand names are for identification purposes only and are acknowledged



S040021:3
For use with firmware versions 85 onwards

Pretorian
TECHNOLOGIES LTD.

Unit 37 Corringham Road Industrial Estate
Gainsborough Lincolnshire DN21 1QB UK
Tel +44 (0) 1427 678990 **Fax** +44 (0) 1427 678992

www.pretorianuk.com
